

The

Faversham

**Compact Solid Fuel
Cast Iron
Cabin Stove**



**Traditional Black
Lead Finish
weight approximately 30 kg
with 25 mm fire bricks
and 75 mm flue
Available with or without fiddle**

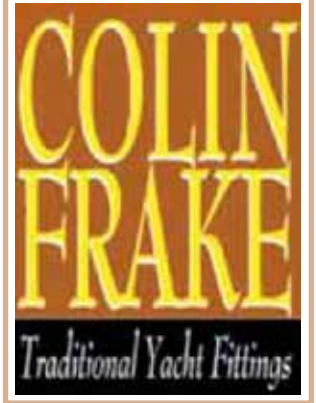

“The Faversham” solid fuel cast iron stove was designed specifically for narrow boats and sea going vessels. Its 25mm fire bricks, top loading and glass opening door features plus being able to be bolted down, make The Faversham a very attractive stove.

The stove is finished in matt black heat resistant paint, as is the fuel pipe, which is sold in straight lengths or can be fabricated when an off-set is required.

Available with or without brass fiddle.

Its ability to stay in for long period of time makes it a “must”. To achieve this, the best fuels we have found are smokeless, although the stove will burn ordinary household coal. Tests have shown that it is not suitable for charcoal.

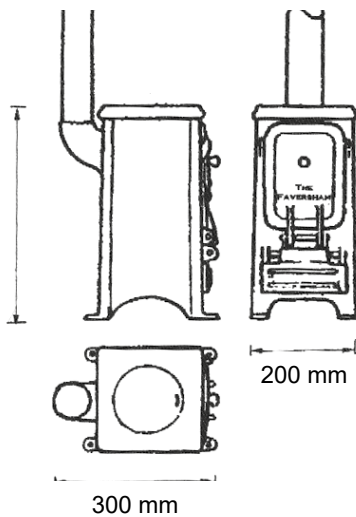

Hinged
(Type B)

Chimneys

approx 18”
Galvanised steel with a
choice of two top fittings



Deck Flange
& cap, Bronze



Deck Flange cap,
Bronze



Deck Flange
& cap, Galvanised



Deck Flange



“The Coolie”
(Type A)



Flue Pipe

75 mm outside diameter, mild steel and painted heat resistant black paint

COLIN FRAKE
TRADITIONAL YACHT FITTINGS
PURIFIER BUILDING
MORRISONS WHARF
NORTH LANE
FAVERSHAM
ME13 7DY

+44 (0)07968 041 322
Email : sales@colinfrake.co.uk

“The Faversham”

Solid Fuel Cast Iron Cabin Stove

ORDER FORM

| Please send me: | weight | unit cost | quantity | total cost |
|--|------------|-------------------------|----------|------------|
| “The Faversham” Cast Iron Cabin Stove in a traditional black lead finish | 30kg | £520.00 | | |
| Plus the following extras: | | | | |
| Brass Fiddle Rail | | 42.50 | | |
| Deck Flange | Galvanised | 1.5kg | 53.00 | |
| | Bronze | 1.5kg | 78.00 | |
| Deck Flange Cap | Galvanized | .75kg | 38.75 | |
| | Bronze | .75kg | 54.50 | |
| Chimney | Type A | 5kg | 63.00 | |
| | Type B | 5kg | 59.00 | |
| Flue Pipe – 75mm Outside Diameter | 6kg | 21.60 per metre | | |
| Fabricated Flue Pipe with Off Set | | From £110.00 | | |
| Carriage - please provide postal/zip code below to allow me to quote | | price on application | | |
| Total Cost > | | | | |

Although, all items are generally in stock to avoid disappointment,
please call to reserve your Stove before sending payment

| Account Name | BIC | IBAN | Sort Code | Account Number |
|--------------|-------------|-----------------------------|-----------|----------------|
| C V Frake | LOYDGB21060 | GB47 LOYD 3091 6002 2203 71 | 30 91 60 | 02220371 |

| | |
|---|---|
| name : full delivery address including post/zip code : | daytime tel no : email <div style="text-align: right; font-size: small;">Oct 17</div> <div style="background-color: #cccccc; padding: 5px; font-weight: bold; font-size: small;"> IMPORTANT : The Stove is well packed for transit but it is essential that there is someone present when the Stove is delivered to examine it in the presence of the carrier. </div> |
|---|---|

PURIFIER BUILDING, NORTH LANE, FAVERSHAM, ME13 7DY

telephone : +44 (0) 7968 041 322

email:sales@colinfrake.co.uk

www.colinfrake-classicyachtfittings.co.uk

PURIFIER BUILDING, NORTH LANE, FAVERSHAM, ME13 7DY

telephone : +44 (0) 7968 041 322

email: sales@colinfrake.co.uk

www.colinfrake-classicyacht fittings.co.uk